

Insulators for steel and other conductive material posts must be high-density polyethylene or polypropylene with ultra-violet (UV) stabilizer, porcelain or other insulators, which can withstand a minimum of 10,000 volts or more in current leakage. Only insulators with a 10-year warranty are of sufficient quality.

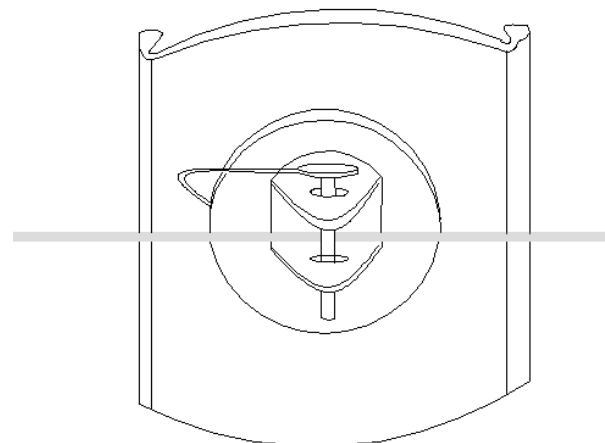

Use a bullnose insulators for electric fence corner braces.

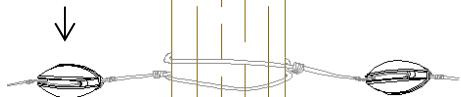

Corner braces are needed for directional changes greater than 20 degrees.

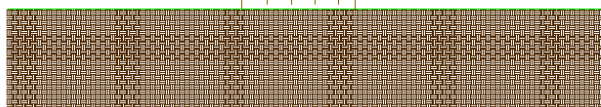

All non-traditional electric fence post should have a 10 year manufactures warranty and have UV protection.

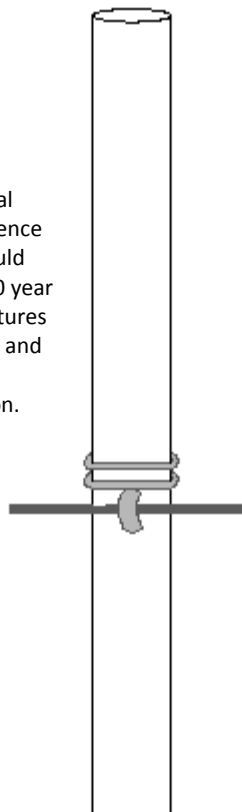

Do not use "step-in" post for permanent electric fence.

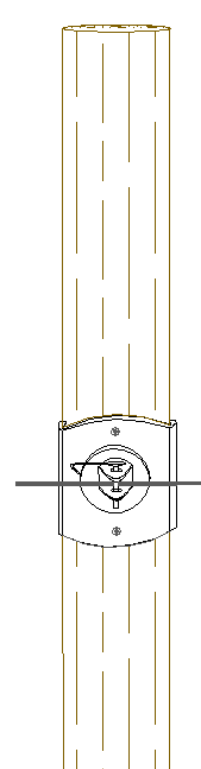

Approved steel or wood post may be used with UV protected insulators with a 10 year warranty.

